



MDT Electronics

Mechanical Interface Issues

GENERAL ISSUES (all Chambers)

Male pins on chambers

Acceptable to electronics group

Maximum pin diameter is 1.9mm due to socket availability

Position tolerance is +/- 200um per mill-max pin spec

Insertion force goes up from 50g/pin to 300g/pin (14kg/board)

Normal force goes up from 50g/pin to 200g/pin

Male pins must be gold plated for reliable contact

Faraday Cage Space

75mm is required for electronics board stack

Tubes must be shortened by 15mm on readout end!

(some space gained by "sex change" but the endplugs have gotten longer)

Faraday Cage Design

Preferred (but perhaps unrealistic) solution is to enclose entire MDT chamber in conductive shield

Maximum acceptable gap in faraday cage is ~1cm slit

ENDCAP CHAMBER ISSUES

ANGLED vs 8-FOLD STEP

Either is acceptable to electronics group

Angled PCB mounting has additional fab and assembly costs
(exact price not known; non-standard processing of boards)

8-fold step results in increased coverage
(mezzanine card fits in extra space)



MDT Electronics

Endplug / PCB Connection-BARREL

NOT TO SCALE

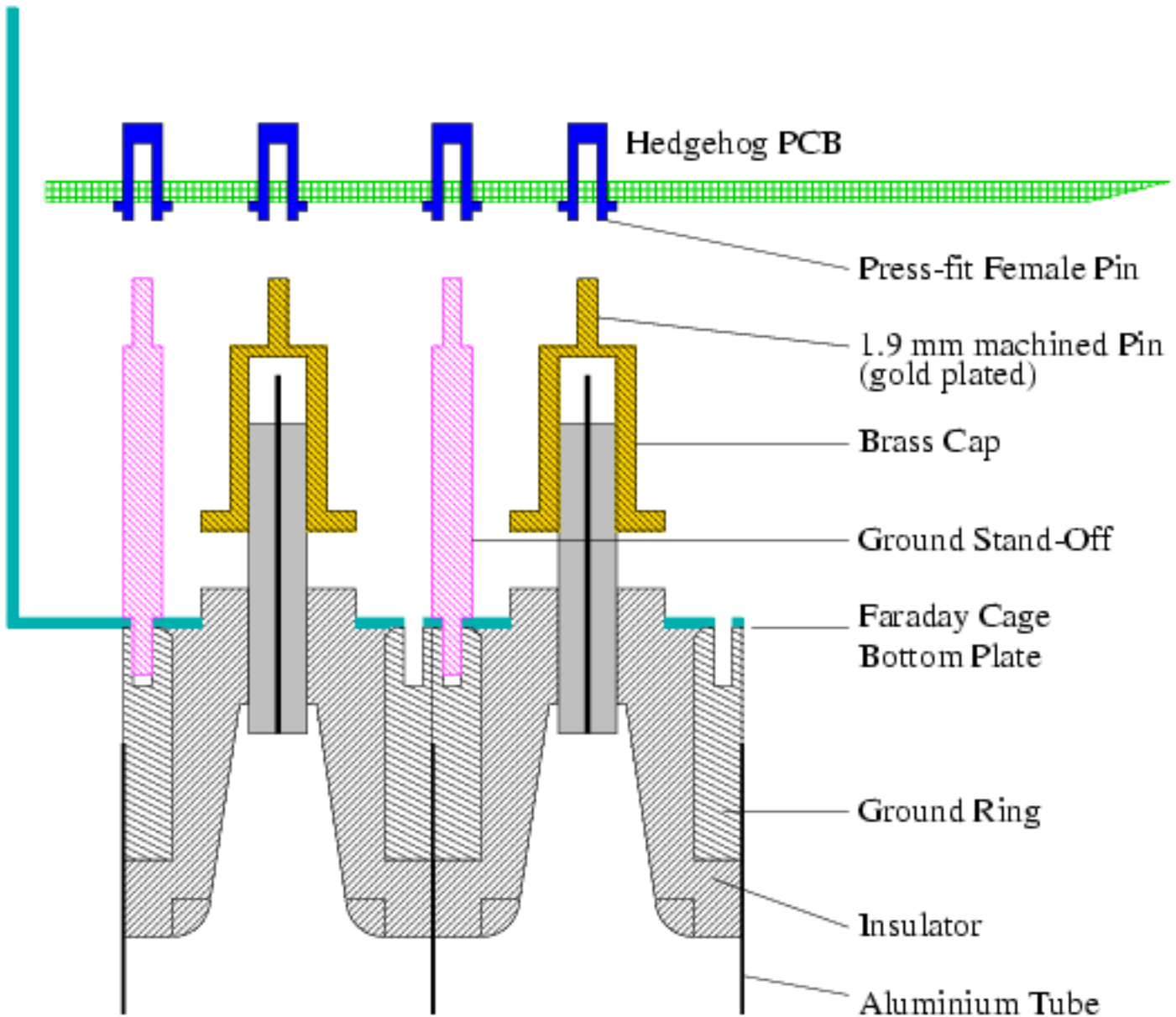

Space for cables, etc is very tight!

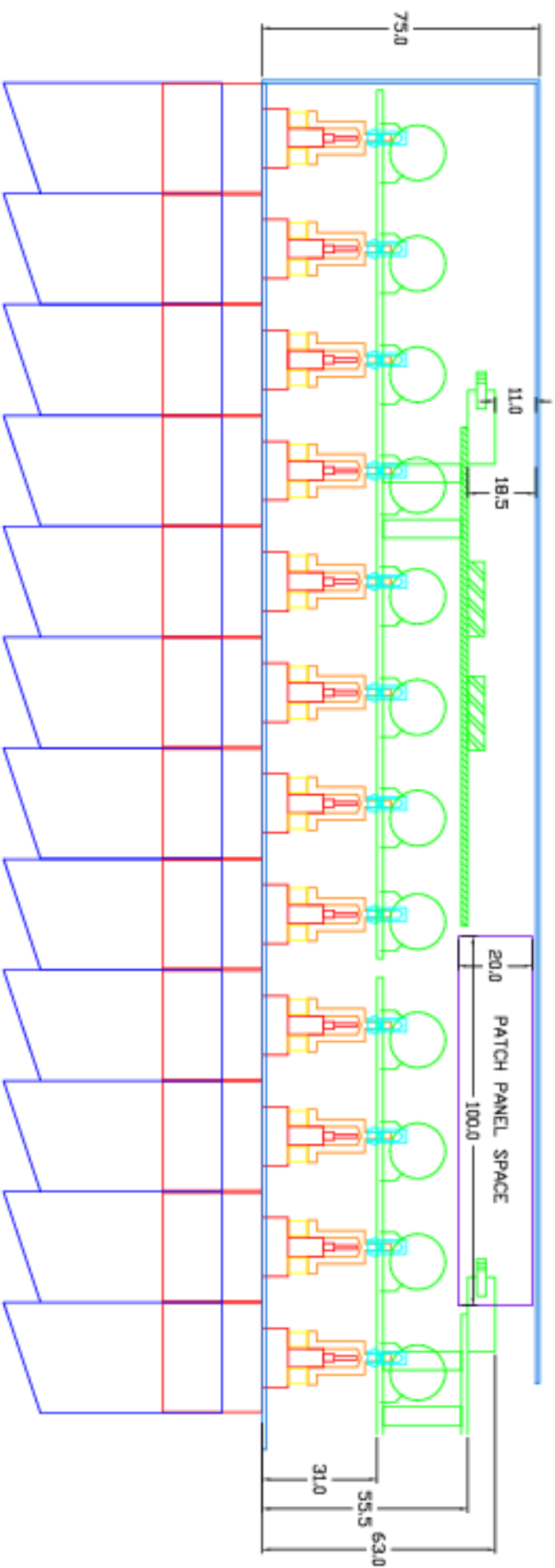

PRELIMINARY!

NOTES: UPDATED to 1998-11-03 Endplug Drawings
TUBES MUST BE SHORTENED 15mm EACH END
TO CONFORM TO M4 ENVELOPE

Boston Muon Consortium <i>Boston University - Electronics Design Facility</i>	
ATLAS MDT Readout BARREL CHAMBER Faraday Cage Interior	
SCALE: DD NDT SCALE	Revision: XXX
Dwg: E. Hazen	Date: 1998-11-11

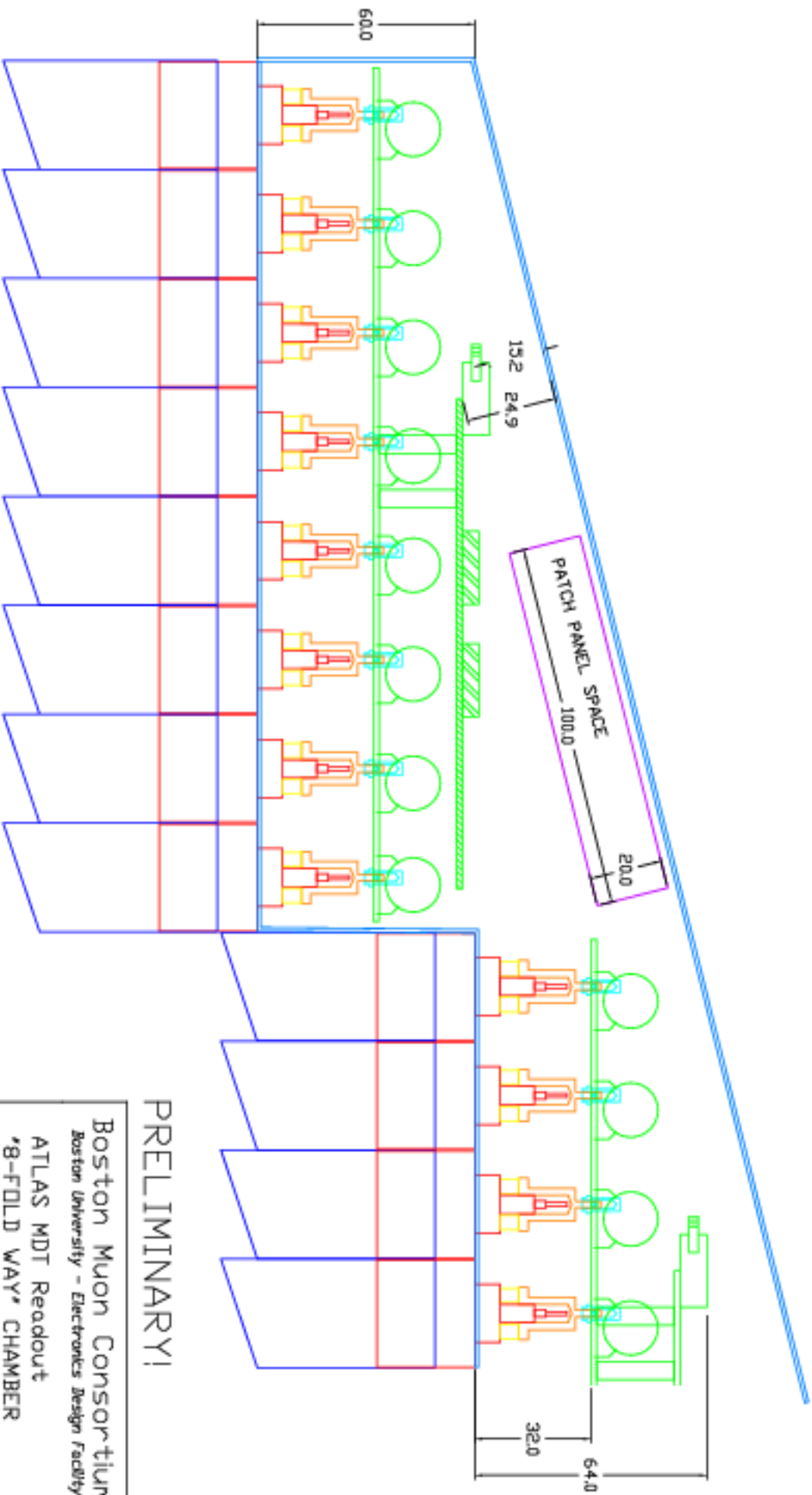

NOTES: Conforms to M4 Chamber envelope
 (7/8 tubes shortened)
 Uses 1998-11-03 Endplug Geometry

PRELIMINARY!

Boston Muon Consortium
 Boston University - Electronics Design Facility
 ATLAS MDT Readout
 '8-FOLD WAY' CHAMBER
 Faraday Cage Interior

SCALE: DD NOT SCALE	Revision	XXX
Dwg: E. Hazen	Date:	2001-11-11